

- Punch or drill correct sized mounting hole in board.
- Place fastener into the anvil as shown.
- With punch and anvil surfaces parallel, apply a steady squeezing force until shoulder of the retainer squarely contacts the sheet metal.

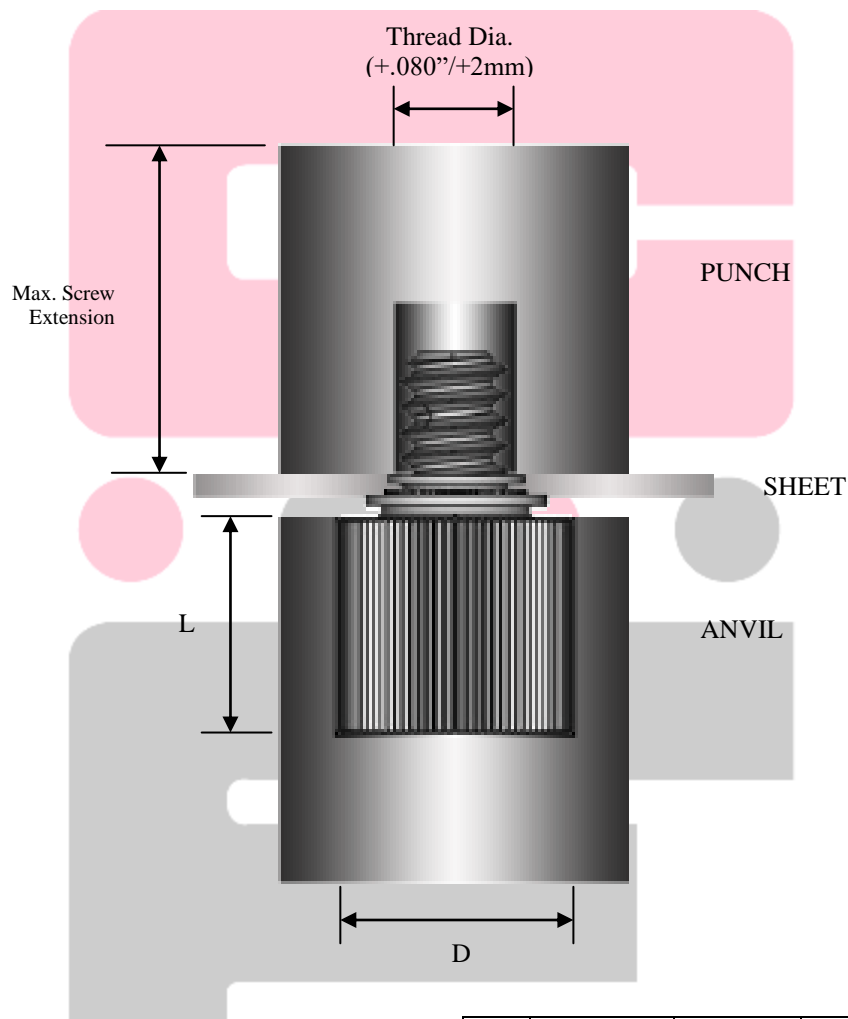

INCH (in.)	Thread Code	D ±0.002	L ±0.002
	440	0.250	0.437
	632	0.390	0.468
	832	0.390	0.531
	1032	0.390	0.531
	420	0.480	0.598

METRIC (mm.)	Thread Code	D ±0.05	L ±0.05
	M3	6.60	11.10
	M3.5	9.91	11.89
	M4	9.91	13.49
	M5	9.91	13.49
	M6	12.19	15.19